

Professional equipment for preparing cold creams, sorbets, and granitas. Designed with a 2.8-liter container to manage small quantities.

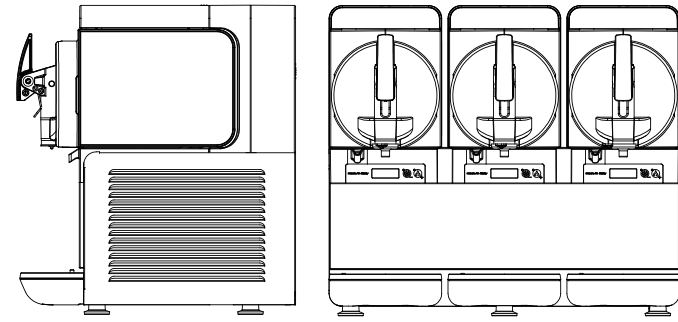

**Certifications**



**Available Voltages**

230V 50Hz / 240V 50Hz / 115V 60Hz / 208-220V 60Hz / 100V 50-60Hz

Technical Specifications	ICON 3/1	ICON 3/2	ICON 3/3
Capacity (L)	2,8	5,6	8,4
Height (cm)	49	49	49
Width (cm)	18	37	55
Depth (cm)	44	44	44
Net weight, approx. (Kg)	20	36	52
Gross weight, approx. (Kg)	22	38	54
Power * (W)	300	500	750
Gas	R290	R290	R290
Gas (220V 60Hz, 100 / 115V 50 / 60Hz)	R134a	R134a	R448a

Additional Technical Features	Safety and control devices
Shatterproof PETG (Tritan) container - BPA free	Noise level below 70 dB (A)
Painted steel body	R290 gas models: equipped with ATEX electrical components
Re-COVER: for energy savings and reduced condensation	Hermetic compressor with protector
POM plastic stirrer	Mechanical product density control
Air-cooled condenser	Electronic product temperature control
Fixed-speed gear reducer	Pre-equipped for tap lock
Mechanical transmission	Easy to disassemble and clean
Lid unlocking button	Day/night function (production/maintenance mode)
	Simple and intuitive control panel

Accessori disponibili (optional)	
Container/lid unlocking with key	Customizable flavor marker
Product lighting	